

Right the First Time

Safe, Accurate, Service Friendly



Tank Weighing

SWC515 PINMOUNT weigh modules offer rugged construction and many features for easy installation and accurate and reliable tank weighing. Two standard lift-off screws cope with wind forces, while two vertical down stops provide additional safety.



Shown with POWERCELL® PDX® load cell



Conveyors and Mixers

SWC515 weigh modules are also designed for dynamic-loading applications such as conveyors, mixers, and blenders. SWC515 provides 360° checking for easy installation and maximum safety. The rocker pin restores the top plate to its ideal position to maintain accurate, repeatable weighing.

Shown with two optional stabilizers



Load Cells

Both analog and POWERCELL® PDX® load cells have a rocker-pin design that automatically aligns load forces for accurate weighing. These hermetically sealed load cells are rated IP68 and can be used in all environments. The load cells are easy to inspect or replace.

Right the First Time

SWC515 PINMOUNT features ensure correct scale system installation, right from the start. PINMOUNT does not compromise on safety – all safety features are built in. The rocker-pin design provides the highest level of weighing accuracy. Service features such as SafeLock™ provide easy and trouble-free installation. SWC515 features:

- Dual integrated lift-off protection
- Dual vertical safety down stop
- Full 360° integrated checking
- Ground strap – welding protection
- SafeLock™ – Weigh module locked for installation
- SafeLock™ – Load cell protected for installation
- Dual stabilizer option
- Capacity range: 7.5t – 100t
- Analog or POWERCELL® PDX® load cell
- IP68 load cell, fully stainless steel
- Global approvals standard on each load cell
- Zinc-plated or stainless steel mounting hardware
- Calibration without test weights



Stabilizers

Up to two optional stabilizers can be applied to each weigh module to stabilize a scale subject to heavy vibration, high torque, or in-motion weighing. With stabilizers installed, thermal expansion is still possible, guaranteeing the best weighing performance.

SWC515 Weigh Module Specifications – Analog

Weigh Module		Unit of Measure	Specification					
Model No.			SWC515 PINMOUNT – Analog					
Size			1		2		3	
Rated Capacity (R.C.)		† (klb, nominal)	7.5 (16.5)	15 (33)	22.5 (49.6)	30 (66)	50 (110)	100 (220)
Load Limit, Safe ⁸	with load cell	%R.C.	150		125		125	
	in shipping mode		100					
Restoring Force ⁵		%A.L./mm (./in) ³	2.4 (61)		3.4 (87)	0.8 (19)	2 (51)	
Max. Horizontal Force ⁶	transverse	kN (klb)	74 (16.5)		100 (22)		130 (28)	
	longitudinal		74 (16.5)		100 (22)		130 (28)	
Max. Horizontal Force (longitudinal) per stabilizer option ⁹		kN (klb)	22 (5)		35 (7.7)		60 (13.4)	
Max. Top Plate Travel	transverse	mm (in)	± 5 (0.2)					
	longitudinal ¹⁰		± 5 (0.2)					
Max. Uplift Force ⁷		kN (klb)	74 (16.5)		150 (33)		260 (57)	
Weight (including load cell), nominal		kg (lb)	20 (44)		55 (120)		75 (165)	
Material			carbon steel/304 stainless steel/316 stainless steel			carbon steel / 304 stainless steel		
Finish			Zinc Plated / Electropolished / Electropolished			Zinc Plated / Electropolished		

Load Cell (SLC610, 0782)		Unit of Measure	Specification					
Model No.			SLC610			0782		
Rated Capacity (R.C.)		† (klb, nominal)	7.5 (16.5)	15 (33)	22.5 (49.6)	30 (66)	50 (110)	100 (220)
Rated Output		mV/V @R.C.	2 ± 0.1 %					
Combined Error ^{1, 2}		%R.C.	≤ 0.018					
Temperature Effect on	Min. Dead Load Output	%R.C./°C (./°F)	≤ 0.0009 (0.0005)			≤ 0.002 (0.001)		
	Sensitivity ²	%A.L./°C (./°F)	≤ 0.0009 (0.0005)					
Temperature Range	Compensated	°C (°F)	-10 ~ +40 (-14 ~ +104)					
	Operating		-40 ~ +80 (-40 ~ +176)		-40 ~ +65 (-40 ~ +150)			
	Safe Storage		-40 ~ +80 (-40 ~ +176)					
OIML / European Approval ⁴	Class		C3					
	nmax		3000					
	Y		15,000		6666			
NTEP Approval ⁴	Class		III M			III LM		
	nmax		6000			10,000		
	Vmin	kg (lb)	0.6 (1.3)	1.3 (2.9)	1.9 (4.2)	2.1 (4.5)	3.5 (7.5)	7.0 (15)
	ATEX Approval ⁴		Zone 0, 1, 20, 21			Zone 1, 2, 21, 22		
Factory Mutual Approval ⁴	Rating		IS/I, II, III/1/ABCDEF/G/T4					
	Excitation Voltage	Recommended	5 ~ 15					
Terminal Resistance	Excitation	Ω	1150 ± 50			1160 ± 10		
	Output		1000 ± 2			1000 ± 3		
Material	Spring Element		stainless steel					
	Type		glass-to-metal seal			welded		
Protection	IP Rating		IP68					
	NEMA Rating		NEMA 6/6P					
Load Limit	Safe	%R.C.	200		125			
	Ultimate		300					
Weight, nominal		kg (lb)	1 (2.2)		3 (6.6)	3.3 (7.3)	4.5 (9.9)	
Cable	Length	m (ft)	12 (39)		13 (42.5)			
	Diameter	mm (in)	5 (0.20)		5.8 (0.23)			



SWC515 Weigh Module Specifications – POWERCELL® PDX®

Weigh Module		Unit of Measure	Specification		
Model No.			SWC515 PINMOUNT – POWERCELL® PDX®		
Size			2		
Rated Capacity (R.C.)		† (klb, nominal)	20 (44)	30 (66)	50 (110)
Load Limit, Safe ⁸	with load cell	%R.C.	125		
	in shipping mode		100		
Restoring Force ⁵		%A.L./mm (./.in) ³	0.8 (19)		2 (51)
Max. Horizontal Force ⁶	transverse	kN (klb)	100 (22)		
	longitudinal		100 (22)		
Max. Horizontal Force (longitudinal) per stabilizer option ⁹		kN (klb)	35 (7.7)		
Max. Top Plate Travel	transverse	mm (in)	± 5 (0.2)		
	longitudinal ¹⁰		± 5 (0.2)		
Max. Uplift Force ⁷		kN (klb)	150 (33)		
Weight (including load cell), nominal		kg (lb)	55 (120)		
Material			carbon steel / 304 stainless steel		
Finish			Zinc Plated / Electropolished		

Load Cell (SLC820)		Unit of Measure	Specification			
Model No.			POWERCELL® PDX®, SLC820			
Rated Capacity (R.C.)		† (klb, nominal)	20 (44)	30 (66)	50 (110)	
Sensitivity at R.C.		d @ R.C.	200,000	300,000	500,000	
Effective System Update Rate (4 cells)		Hz	83			
Temperature Range	Compensated	°C (°F)	-10 ~ +40 (+14 ~ +104)			
	Operating		-30 ~ +55 (-22 ~ +131)			
	Safe Storage		-40 ~ +80 (-40 ~ +176)			
OIML / European Approval ⁴	Class		C3	C3	C4	C3
	nmax		3000	3000	4000	3000
	vmin	kg	3.5	4.7	2.4	5.7
NTEP Approval ⁴	Class		III L M	III L M	n/a	III L M
	nmax		10,000	10,000	n/a	10,000
	vmin	lb	2.9	3.9	n/a	4.8
ATEX Approval ⁴			Zone 2, 22			
IECEX			Ex nA II T6; Ex tD A22 IP6X T 85°C			
UL Approval, USA / Canada ⁴			Class I, II, III, Division 2, Groups C, D, E, F, G			
Supply Voltage Non-regulated	Typical	V DC	12-24 (external supply)			
Lightning Protection	Max. Tested (IEEE4-95)	A	≥ 80,000			
Material	Spring Element		stainless steel			
	Enclosure		304 stainless steel, Electropolished			
	Cable		Braided Stainless Steel, Oil Resistant, 9mm, 5 Conductors, Internal/External Shielded with Drain Wires			
	Connectors		Quick-Connect, Stainless Steel, Glass-to-Metal			
Protection	IP Rating		IP68 (1m - 7 day submersion) IP69K test reports on file			
	NEMA Rating		NEMA 6P (submersible)			

¹ Error due to the combined effect of non-linearity and hysteresis.

² Typical values only. The sum of errors due to Combined Error and Temperature Effect on Sensitivity comply with the requirements of OIML R60 and NIST HB44.

³ A.L. = Applied Load.

⁴ See certificate for complete information.

⁵ % of Applied Load (A.L.) per mm (in) displacement of the top plate (transverse & longitudinal).

⁶ Maximum horizontal force that can be applied to the top plate.

⁷ Maximum vertical uplift force that can be applied to the top plate.

⁸ Maximum vertical downward force that can be applied to the top plate.

⁹ 1 or 2 per weigh module. Max permissible longitudinal force per stabilizer.

¹⁰ 0 with stabilizer.



SWC515 Weigh Module Dimensions mm [inch]

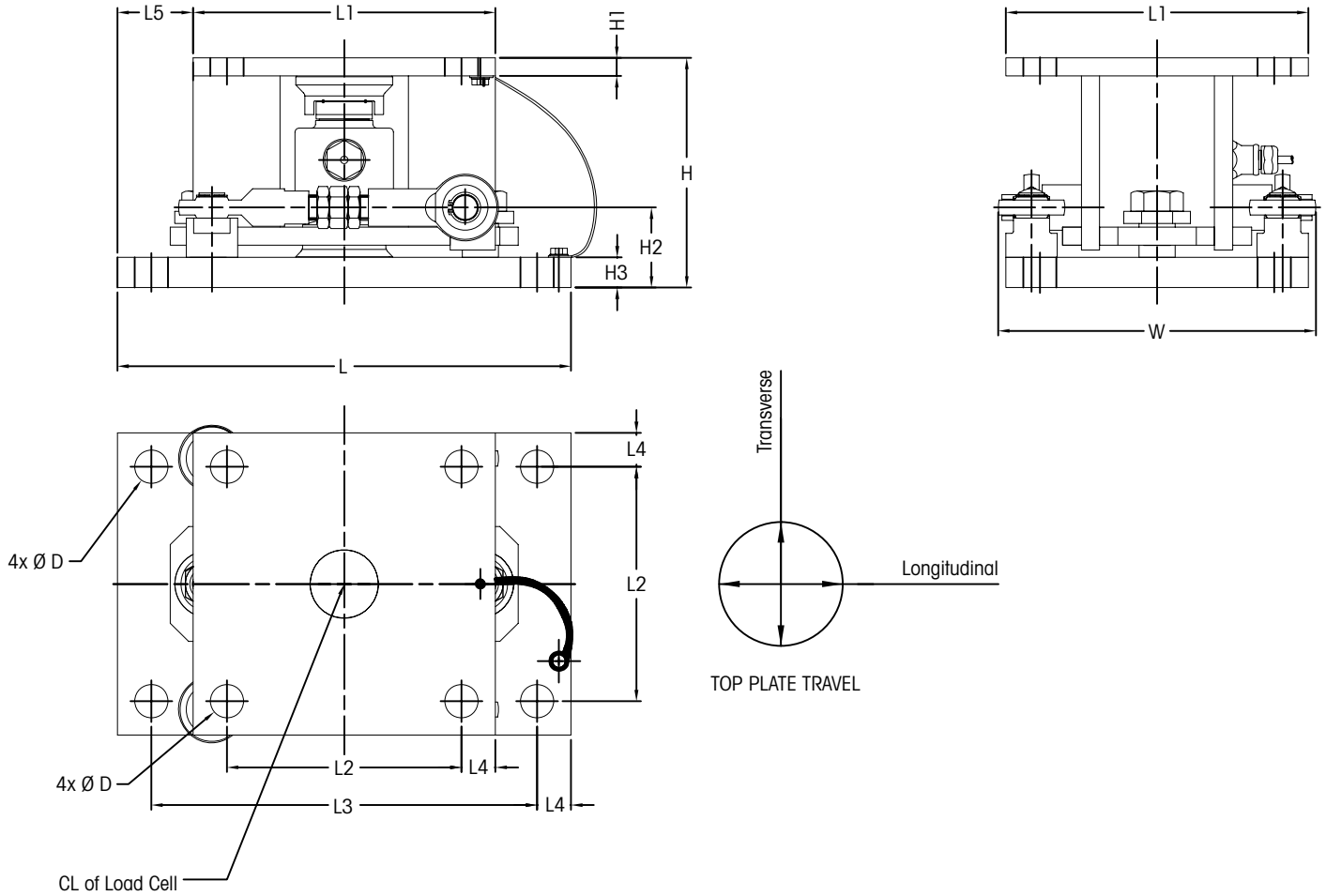

SWC515 Weigh Module – Size 1

Size	Capacity	Dimensions and Locations											Tank Leg Plate		
		D	H	H1	H2	H3	L	L1	L2	L3	L4	L5	W	Thickness	Dimensions
1	7.5, 15, 22.5t	22.0	152.0	12.0	53.0	20.0	300.0	200.0	155.0	255.0	22.5	50.0	210.0	min 25	200 x 200
	[16.5, 33, 49.6 klb]	[0.87]	[5.98]	[0.47]	[2.09]	[0.79]	[11.81]	[7.87]	[6.10]	[10.04]	[0.89]	[1.97]	[8.27]	[1.0]	[7.9 x 7.9]
2	20, 30, 50t	26.0	235.0	23.0	68.0	28.0	365.0	250.0	200.0	315.0	25.0	22.5	273.0	min 50	250 x 250
	[44, 66, 110 klb]	[1.02]	[9.25]	[0.91]	[2.68]	[1.10]	[14.37]	[9.84]	[7.87]	[12.40]	[0.98]	[0.89]	[10.75]	[2.0]	[9.8 x 9.8]
3	100t	32.0	263.0	30.0	91.0	33.0	440.0	300.0	235.0	375.0	32.5	30.0	324.0	min 60	300 x 300
	[220 klb]	[1.26]	[10.35]	[1.18]	[3.58]	[1.30]	[17.32]	[11.81]	[9.25]	[14.76]	[1.28]	[1.18]	[12.75]	[2.4]	[11.8 x 11.8]

Dimensions in mm [inches].

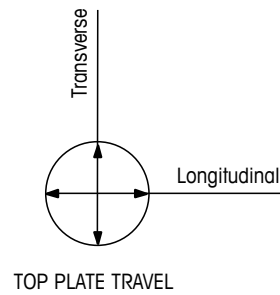
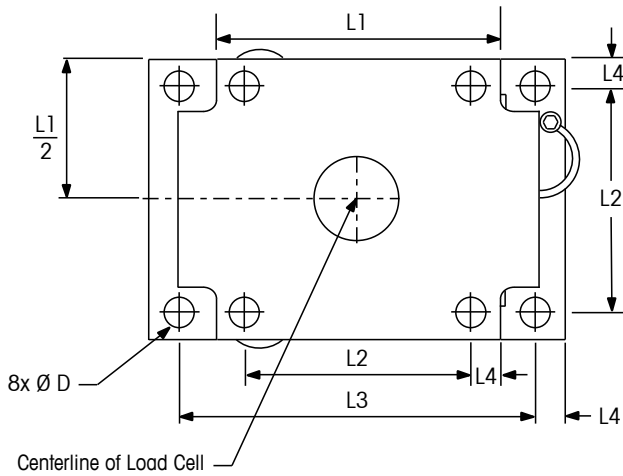
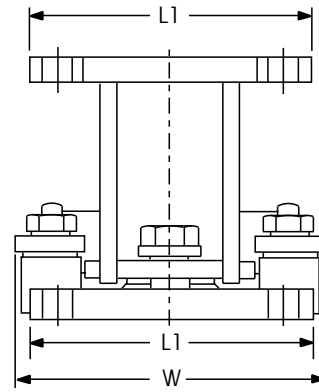
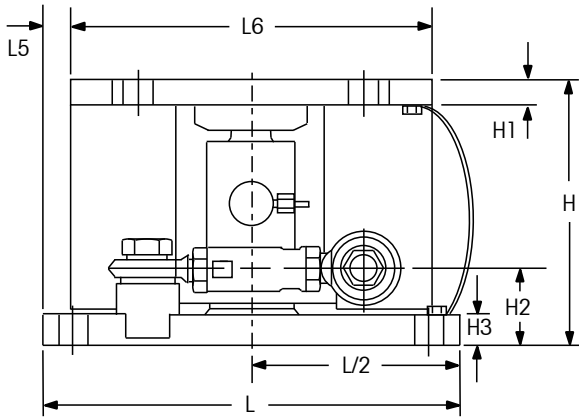

SWC515 Weigh Module – Size 2/3

SWC515 Weigh Module Arrangements

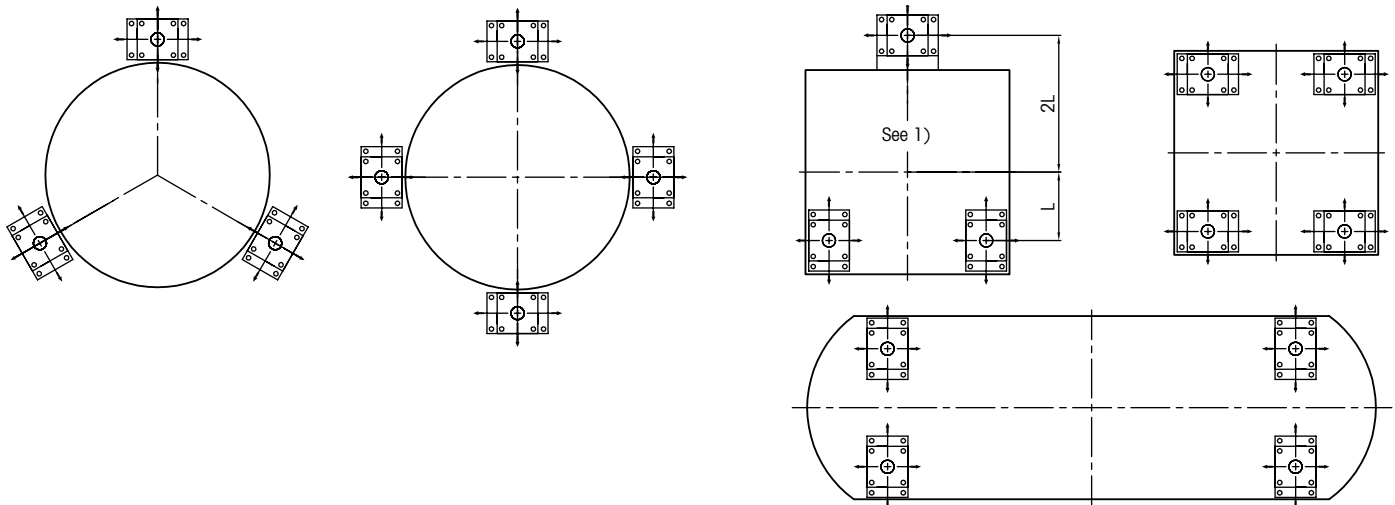

1) Provides equal load distribution, but the stability of this arrangement must be assured.

SWC515 Order Information, Size 1, 7.5 – 22.5t

Weigh Module Assembly SWC515 (including SLC610 analog load cell) Size 1	Zinc Plated	304 Stainless Steel	316 Stainless Steel
Weigh Module Assembly, analog, Size 1, 7.5t C3/III M n:6	72205446	72205449	72247331
Weigh Module Assembly, analog, Size 1, 15t C3/III M n:6	72205447	72205450	72247332
Weigh Module Assembly, analog, Size 1, 22.5t C3/III M n:6	72205448	72205451	72247181

Weigh Module Kit SWC515 (without load cell) Size 1	Suitable Load Cell				
Weigh Module Kit, analog, Size 1, 7.5t – 22.5t	72205442	72205443	72245084	7.5t C3/III M n:6 72205433	7.5t C4/III M n:6 72218332
				15t C3/III M n:6 72205434	15t C4/III M n:6 72218333
				22.5t C3/III M n:6 72205435	22.5t C4/III M n:6 72218334
				Dummy Load Cell SLC610, 72206152	All SLC610 Load Cells

Options, SWC515 Size 1

Stabilizer Size 1*, 7.5t – 22.5t	72205444	72205445	72242585
Spacer Plate Size 1, 7.5t – 22.5t	72245532	72206153	72247333
Dead Stand Size 1, 7.5t – 22.5t	72206154	72206155	–
Shock/Vibration Pad (includes Spacer Plate) Size 1, 7.5t – 22.5t	72246646	72207262	72247334
Thermal Isolation Pad 80°C (includes Spacer Plate) Size 1, 7.5t – 22.5t	72246647	72207263	72247335
Thermal Isolation Pad 170°C (includes Spacer Plate) Size 1, 7.5t – 22.5t	72246648	72207264	72247336

SWC515 Order Information, Size 2, 20 – 50t

Weigh Module Assembly SWC515 (including 0782 analog load cell) Size 2	Zinc Plated	304 Stainless Steel	316 Stainless Steel
Weigh Module Assembly, analog, Size 2, 30t C3/III M n:10	72249169	72249170	–
Weigh Module Assembly, analog, Size 2, 50t C3/III M n:10	72249204	72249205	–

Weigh Module Assembly SWC515 (including POWERCELL® PDX® load cell) Size 2

Weigh Module Assembly, POWERCELL® PDX®, Size 2, 20t C3/III M n:10	72262440	72262441	–
Weigh Module Assembly, POWERCELL® PDX®, Size 2, 30t C3/III M n:10	72255118	72255120	–
Weigh Module Assembly, POWERCELL® PDX®, Size 2, 50t C3/III M n:10	72255119	72255121	–

Weigh Module Kit SWC515 (without load cell) Size 2	Suitable Load Cell				
Weigh Module Kit, analog, Size 2, 30t – 50t	72248964	72248965	–	30t C3/III M n:10 71201709	50t C3/III M n:10 71201710
				Dummy Load Cell 0782 20t – 50t, 72188111	
Weigh Module Kit, POWERCELL® PDX®, Size 2, 20t – 50t	72255116	72255117	–	20t C3/III M n:10 42904882	
				30t C3/III M n:10 42904883	30t C4 42904884
				50t C3/III M n:10 42904891	50t C4 42904892
				Dummy Load Cell PDX 72255084	

Options, SWC515 Size 2

Stabilizer Size 2*, 20t – 50t	72248968	72248969	–
Spacer Plate Size 2, 20t – 50t	72249203	72249206	–
Dead Stand Size 2, 20t – 50t	72249173	72249174	–
Shock/Vibration Pad (includes Spacer Plate) Size 2, 20t – 50t	72255072	72255075	–
Thermal Isolation Pad 80°C (includes Spacer Plate) Size 2, 20t – 50t	72255073	72255076	–
Thermal Isolation Pad 170°C (includes Spacer Plate) Size 2, 20t – 50t	72255074	72255077	–

Bolded entries are stocked

* 1 or 2 per weigh module.

SWC515 Order Information, Size 3, 100t

Weigh Module Assembly SWC515 (including 0782 analog load cell) Size 3	Zinc Plated	304 Stainless Steel	316 Stainless Steel	
Weigh Module Assembly, analog, Size 3, 100t C3/III M n:10	72249171	72249172	–	
Weigh Module Kit SWC515 (without load cell) Size 3				Suitable Load Cell
Weigh Module Kit, analog, Size 3, 100t	72248966	72248967	–	100t C3/III M n:10 71201711
				Dummy Load Cell 0782 100t 72188112
Options, SWC515 Size 3				
Stabilizer Size 3*, 100t	72248970	72248971	–	
Spacer Plate Size 3, 100t	72249213	72249214	–	
Dead Stand Size 3, 100t	72249175	72249176	–	
Shock/Vibration Pad (includes Spacer Plate) Size 3, 100t	72255078	72255081	–	
Thermal Isolation Pad 80°C (includes Spacer Plate) Size 3, 100t	72255079	72255082	–	
Thermal Isolation Pad 170°C (includes Spacer Plate) Size 3, 100t	72255080	72255083	–	

Order Information, POWERCELL PDX Cables

Cable Kit 3x POWERCELL® PDX® load cell, 5m length and termination	61045291
Cable Kit 3x POWERCELL® PDX® load cell, 10m length and termination	61045292
Cable Kit 4x POWERCELL® PDX® load cell, 5m length and termination	61045293
Cable Kit 4x POWERCELL® PDX® load cell, 10m length and termination	61045294
Home Run Cable available from 10 m to 300 m in 10m steps	61044730 – 61044765

Bolded entries are stocked

* 1 or 2 per weigh module.



Predictive Diagnostics

Monitor single load cells for overload, temperature, breach detection, zero drift, etc., and enable reaction before system shuts down or measures incorrectly.

SLC610 Cable Colors

Color	Function
Green	+ Excitation
Black	- Excitation
White	+ Signal
Red	- Signal
Yellow	Shield

0782 Cable Colors

Color	Function
Green	+ Excitation
Black	- Excitation
White	+ Signal
Red	- Signal
Yellow	+ Sense
Blue	- Sense
Yellow (long)	Shield

Full Connectivity

METTLER TOLEDO supplies various data communication interfaces that enable our sensors and instruments to communicate with your PLC, MES, or ERP systems.

METTLER TOLEDO Service

Our extensive service network is among the best in the world and ensures maximum availability and service life of your product.



Weighing Electronics

METTLER TOLEDO offers a complete family of electronics from simple weighing to application solutions for filling, stock control, batching, formulation, counting, and checkweighing.

www.mt.com/weighmodule

For more information

Produced in a
facility that is



Mettler-Toledo, LLC

1900 Polaris Parkway
Columbus, Ohio 43240
Tel. (800) 786-0038
(614) 438-4511
Fax (614) 438-4900

Specifications subject to change without notice.
© 2012 Mettler-Toledo, LLC
07/2012
TH03472.1E